

SECURITY LATCH

- SECURITY LATCH is an investment in protection and safety. It has many benefits over standard methods of panic door retaining devices. Here's why ...
- FIRE SAFETY – Secures Panic Doors without chains or padlocks ... allows fire fighters immediate exit from a building ... eliminates the possibility of being trapped in a burning building.
- TIME SAVER – Saves employee time securing a building because of the simplicity of application, removal and storage.
- LOW COST – The average school can be equipped with Security Latch for less than the insurance deductible incurred as the result of one break-in.

SAFE, MAR-PROOF SURFACE

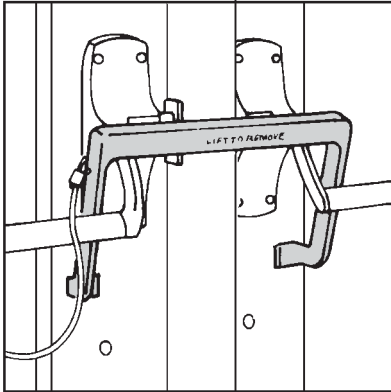

MODEL SL-200 OR SL-205*
\$38.50 ea.
\$49.00 ea.
DOUBLE DOOR LATCH
Wedges firmly against the center post.

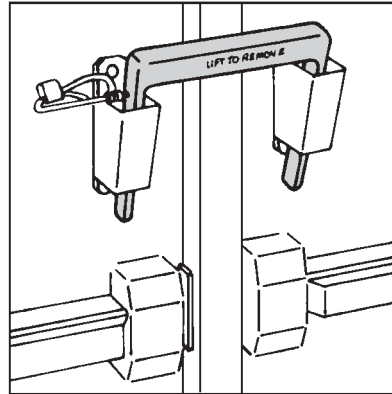

MODEL SL-400 OR SL-405*
\$49.50 ea.
\$59.75 ea.
DOUBLE DOOR LATCH
Wedges firmly against the center post.

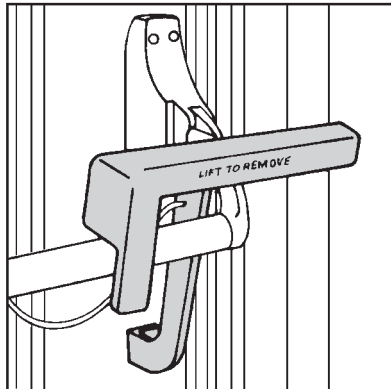

MODEL SL-120 OR SL-125*
\$38.50 ea.
\$49.00 ea.
SINGLE DOOR LATCH
Wedges firmly against the door jamb.
(Specify right or left hand door)
(Right hand shown)

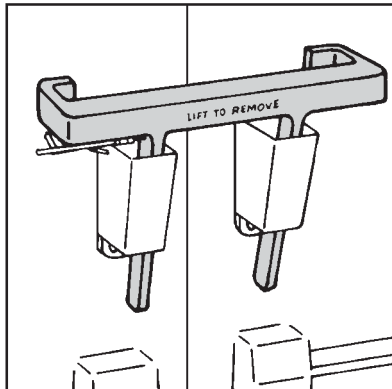

MODEL SL-410 OR SL-415*
\$52.00 ea.
\$62.50 ea.
DOUBLE DOOR LATCH
For doors without a center post.

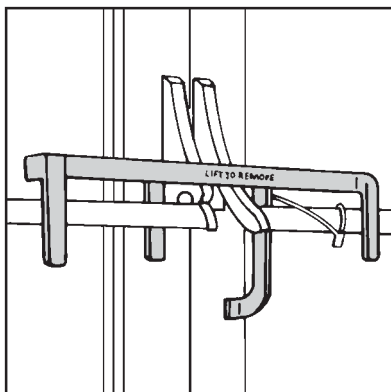

MODEL SL-210 OR SL-215*
\$46.50 ea.
\$56.50 ea.
DOUBLE DOOR LATCH
For doors without a center post.

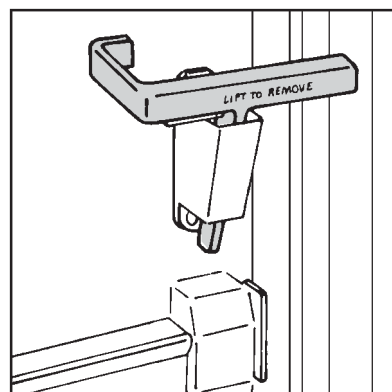

MODEL SL-420 OR SL-425*
\$44.75 ea.
\$54.75 ea.
SINGLE DOOR LATCH
Wedges firmly against door jamb.
(Specify right or left hand door)
(Right hand shown)

*SECURITY LATCH EQUIPPED WITH CABLE LOCK.

WWW.CENTARIND.COM
e-mail:
CUSTSERVICE@CENTARIND.COM



Centar Industries INCORPORATED
16313 WESTWOODS BUSINESS PARK, ELLISVILLE, MO 63021
CALL TOLL FREE: 1-800-843-7878 • FAX 1-636-391-2336

IN ST. LOUIS CALL:
636-391-2333